

LOAD ZONE™

Conveyor Belt Load Zone Support System

Impact Bed



ARGONICS
ENGINEERED POLYURETHANE

LOAD ZONE™ Impact Bed

Conveyor Belt Load Zone Support System

⚠ WARNING ⚠

SAFETY FIRST! Empty conveyor belt of all debris.

Always obey all applicable safety rules. Be sure all power to the conveyor has been disconnected and controls are locked out.

Installation Tools Required

- Tape measure
- Framing Square
- 1 1/16" Diameter Drill Bit
- Cutting Torch
- Center Punch
- 3/4" End Wrench, Socket or Crescent Wrench
- Level
- Dead Blow Mallet
- 5/8"-11 UNC Grade 8 Bolts w/Nuts & Washers
- Scribe or Chalk
- Welder or Drill

Sizing Chart

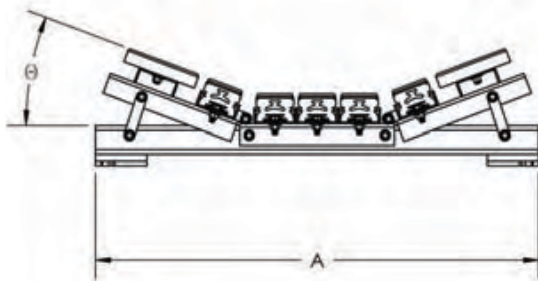

NOTE:
 $\theta = 20^\circ, 35^\circ, 45^\circ$

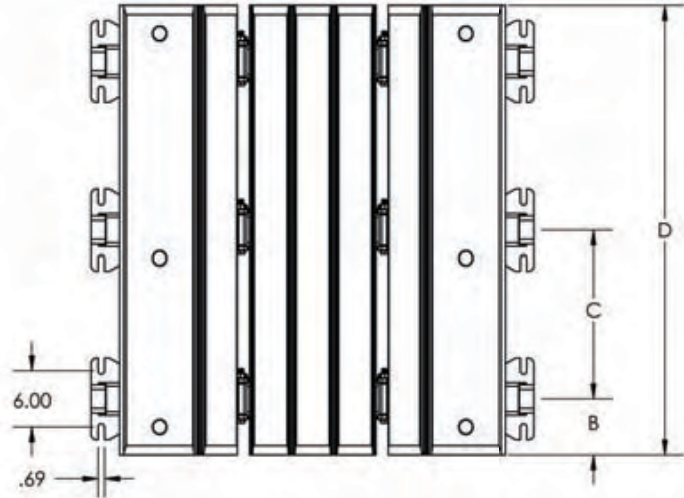

Prefix	L=Light M=Med	Bed Type S=Slide I=Impact R=Roll/ Slide	Idler Class	Bed Length 1=18" 3=36" 4=48" 5=60" 6=70"	Belt Width	N=Normal W=Wide	Options P=Powder S=304SS R=316SS	Trough Angle 20° 35° 45°	Part Numbers	Dim "A"	Dim "B"	Dim "C"	Dim "D"	Impact Bar Qty	Slide Bar Qty	Slide Bar Width
CP-LZ	M	I	YY	4	24	N	P	XX	CP-LZ-MIYY-424NP-XX	35.25	6.00	18	48	4	2	4.00
CP-LZ	M	I	YY	5	24	N	P	XX	CP-LZ-MIYY-524NP-XX	35.25	6.00	24	60	4	2	4.00
CP-LZ	M	I	YY	6	24	N	P	XX	CP-LZ-MIYY-624NP-XX	35.25	6.00	24	72	4	2	4.00
CP-LZ	M	I	YY	4	30	N	P	XX	CP-LZ-MIYY-430NP-XX	41.25	6.00	18	48	4	2	6.00
CP-LZ	M	I	YY	5	30	N	P	XX	CP-LZ-MIYY-530NP-XX	41.25	6.00	24	60	4	2	6.00
CP-LZ	M	I	YY	6	30	N	P	XX	CP-LZ-MIYY-630NP-XX	41.25	6.00	24	72	4	2	6.00
CP-LZ	M	I	YY	4	36	N	P	XX	CP-LZ-MIYY-436NP-XX	47.25	6.00	18	48	5	2	8.00
CP-LZ	M	I	YY	5	36	N	P	XX	CP-LZ-MIYY-536NP-XX	47.25	6.00	24	60	5	2	8.00
CP-LZ	M	I	YY	6	36	N	P	XX	CP-LZ-MIYY-636NP-XX	47.25	6.00	24	72	5	2	8.00
CP-LZ	M	I	YY	4	42	N	P	XX	CP-LZ-MIYY-442NP-XX	53.25	6.00	18	48	7	2	5.00
CP-LZ	M	I	YY	5	42	N	P	XX	CP-LZ-MIYY-542NP-XX	53.25	6.00	24	60	7	2	5.00
CP-LZ	M	I	YY	6	42	N	P	XX	CP-LZ-MIYY-642NP-XX	53.25	6.00	24	72	7	2	5.00
CP-LZ	M	I	YY	4	48	N	P	XX	CP-LZ-MIYY-448NP-XX	59.25	6.00	18	48	8	2	7.00
CP-LZ	M	I	YY	5	48	N	P	XX	CP-LZ-MIYY-548NP-XX	59.25	6.00	24	60	8	2	7.00
CP-LZ	M	I	YY	6	48	N	P	XX	CP-LZ-MIYY-648NP-XX	59.25	6.00	24	72	8	2	7.00
CP-LZ	M	I	YY	4	54	N	P	XX	CP-LZ-MIYY-454NP-XX	65.25	6.00	18	48	10	2	4.00
CP-LZ	M	I	YY	5	54	N	P	XX	CP-LZ-MIYY-554NP-XX	65.25	6.00	24	60	10	2	4.00
CP-LZ	M	I	YY	6	54	N	P	XX	CP-LZ-MIYY-654NP-XX	65.25	6.00	24	72	10	2	4.00
CP-LZ	M	I	YY	4	60	N	P	XX	CP-LZ-MIYY-460NP-XX	71.25	6.00	18	48	10	2	6.00
CP-LZ	M	I	YY	5	60	N	P	XX	CP-LZ-MIYY-560NP-XX	71.25	6.00	24	60	10	2	6.00
CP-LZ	M	I	YY	6	60	N	P	XX	CP-LZ-MIYY-660NP-XX	71.25	6.00	24	72	10	2	6.00
CP-LZ	M	I	YY	4	72	N	P	XX	CP-LZ-MIYY-472NP-XX	83.25	6.00	18	48	13	2	5.00
CP-LZ	M	I	YY	5	72	N	P	XX	CP-LZ-MIYY-572NP-XX	83.25	6.00	24	60	13	2	5.00
CP-LZ	M	I	YY	6	72	N	P	XX	CP-LZ-MIYY-672NP-XX	83.25	6.00	24	72	13	2	5.00

NOTE: Beds are available in 20, 35, & 45 degree angles. Wide frame beds are Dim "A" + 6".

INSTALLATION

Step 1: Preparation

Conveyor should be free of material. Lock Out/Tag Out the conveyor as well as the equipment feeding the conveyor. Brace up belt to allow ample area to complete work. Remove the idlers where the Load Zone bed will be placed. Idlers should be removed so that there is a minimum of ½" and a maximum of 6" space between the idler and the Load Zone bed at both the head end and tail end of the bed. Once the idlers have been removed, clean the frame mounting surface. Make sure the mounting frame surface is flat and straight.

Step 2: Setup

Slide the Load Zone bed under the conveyor belt. Install all required Load Zone beds in this same manner. Be sure to have a minimum of ½" and a maximum of 6" space between the Load Zone beds and idlers. If using more than one bed be sure to leave a set of idlers between each bed.

Clearance Requirements

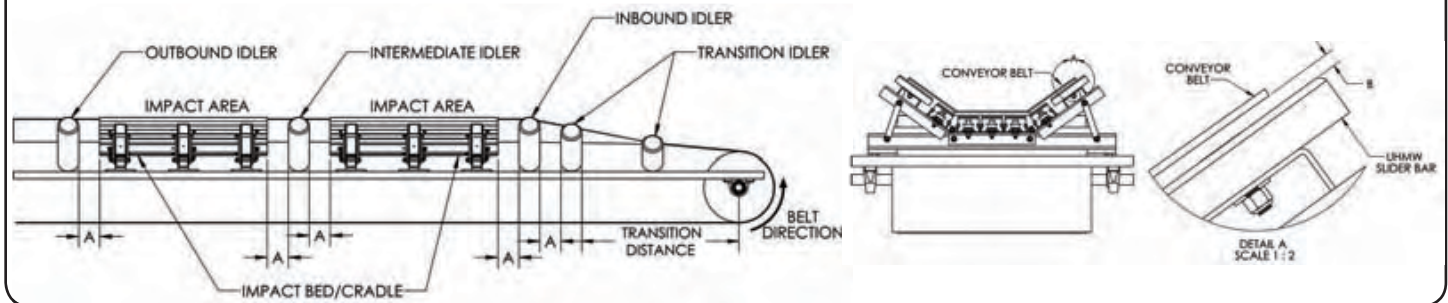

Step 3: Alignment

Follow the above diagram for the clearance requirements and for multiple bed layouts. We recommend the support surface of the Load Zone be ¼" to ½" below the bottom of the conveyor belt and the top of the idler can. Clearance between the idler and the bed should be a minimum of ½", and a maximum of 6". The raised idlers between beds support the conveyor belt during empty conditions, which reduces frictional heat buildup and bed/belt wear.

If you need to shim the bed, please contact Argonics about ordering a shim kit for best support.

With a tape measure, be sure the Load Zone bed is centered on the conveyor frame. Square the bed to the frame with a carpenter's square. Level the bed across the conveyor frame perpendicular to the belt's direction.

Check all your clearances!

At this time, you may choose to weld or bolt the bed into position. We do not recommend welding as it will make bar replacement difficult during future maintenance repairs. For bolting, mark the position for your holes by scribing out the slotted foot openings onto the conveyor frame. Slide the bed out of the way and drill an 1 1/16" hole at all marked locations. Slide the Load Zone bed back into position, check that bed is square and bolt down.

Torque Note:

If bolting into position, use 5/8"-11 UNC grade 8 or higher bolts and washers torqued to 190 ft-lbs. All assembly bolts should be torqued to 90 ft-lbs.

LOAD ZONE™ Impact Bed

Conveyor Belt Load Zone Support System

Step 4: Final Adjustments

Once the bed is mounted, lift one side of carriage to the proper degree and then brace securely. Mount spacer, angle support bracket, bolts and washers, per Figure 1. Make sure angle support brackets are mounted the correct way. It is recommended that you loosely assemble the middle support bracket first, then assemble the remaining support brackets. Once all brackets are loosely assembled, remove the brace and go back and fully tighten all bolts.

Once wing carriage side is complete, repeat on other side of bed.

Step 5: Completion

Check all clearances and measurements. Remove any braces holding up belt. If fully complete, remove any remaining tools and Lock Out/Tag Out. Your Load Zone support system is now installed and ready for use. Follow the proper start-up procedures for your conveyor belt system.

